

FCU Connection module

LEFT GLARE	Wire	Note
+Vcc	1	12V
AUTOLAND LIGHT	2	CPT T1
MASTER WARNING LIGHT	3	CPT T3
MASTER CAUTION LIGHT	4	CPT T2
CPT SSPRIO LIGHT	5	CPT T0

RIGHT GLARE	Wire	Note
+Vcc	1	12V
AUTOLAND LIGHT	2	CPT T1
MASTER WARNING LIGHT	3	CPT T3
MASTER CAUTION LIGHT	4	CPT T2
FO SSPRIO LIGHT	5	FO T0

LEFT BORDER	Wire	Note
COMMON PB GROUP 0	1	PB GROUP 0
GPWS/GS PB	2	PB CHANEL 5
+Vcc	3	12V
GPWS/GS LIGHT	4	MAIN T0

RIGHT BORDER	Wire	Note
COMMON PB GROUP 0	1	PB GROUP 0
GPWS/GS PB	2	PB CHANEL 5
+Vcc	3	12V
GPWS/GS LIGHT	4	MAIN T0

THRUST	Wire	Note
COMMON PB GROUP 4	1	PB GROUP 4
ENG 1 MASTER	2	PB CHANEL 2
ENG 2 MASTER	3	PB CHANEL 3
IGN MODE CRANK	4	PB CHANEL 4
IGN MODE START	5	PB CHANEL 5
SPOILERS ARMED	6	PB CHANEL 6
PARK BRAKE	7	PB CHANEL 7

OVERHEAD BUS	Wire	Note
BUS @0	1	
BUS @1	2	
BUS @2	3	
BUS ADF	4	
BUS VOR	5	

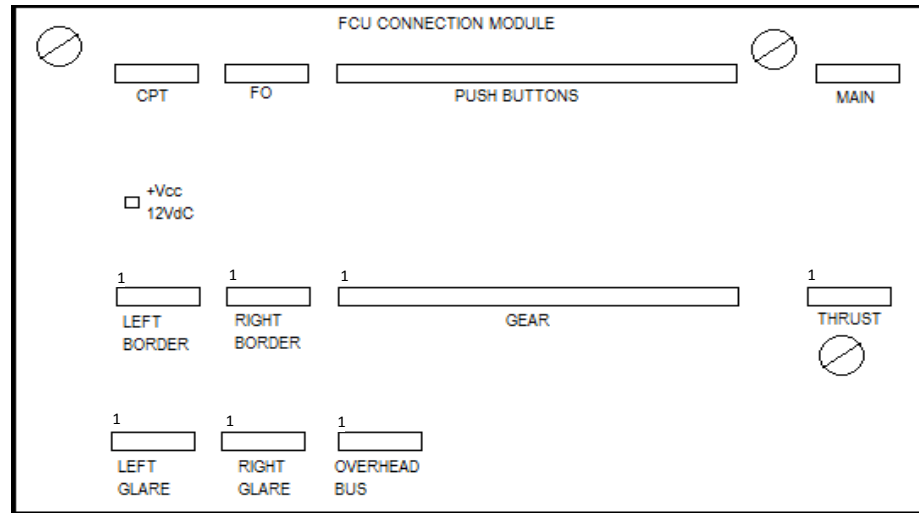

GEAR	Wire	Note
COMMON PB GROUP 5	1	PB GROUP 5
+Vcc	2	12V
LO PB	3	PB CHANEL 3
LO LIGHT	4	FO T1
MED PB	5	PB CHANEL 4
MED LIGHT	6	FO T2
MAX PB	7	PB CHANEL 5
MAX LIGHT	8	FO T3
FAN PB	9	PB CHANEL 2
FAN LIGHT	10	MAIN T1
ANTI SKID SWITCH	11	PB CHANEL 6
GEAR CONTROL	12	PB CHANEL 7
COMMON PB GROUP 6	13	PB GROUP 6
CPT TERR ON ND PB	14	PB CHANEL 0
CPT TERR ON ND LIGHT	15	MAIN T2
FO TERR ON ND PB	16	PB CHANEL 1
FO TERR ON ND LIGHT	17	MAIN T3

Note: Thrust & Overhead BUS are not used in the current simu version.